

Technical Rider Araké

Circus techniques: Rope, Ropes

Performer : Clara Larcher

Rigging for outdoor performances: aerial rig available

Technician: Two options to be discussed with the festival during negotiation

1- Arrange a technical assistance on the festival-- see page 2

2- Traveling with a technician



Contact:
arakeshow@gmail.com
+39 3887313406



Contact in France
muriel.verdiere@pendulaire.fr
+33 7 49226199



Space requirements

Space: 8mx8m

Height : 7m

Floor: regular and flat

Public: half circle

Time requirements

Set up to be arranged the day before or in the morning. not in the sunniest hours of the day

Set Up: 2 hours-one or two assistants needed

Time needed to warm up and rehearse: 3 hours

Show duration : 40 min

Time needed between shows: 90 min

Desmantle: 1 hour- one or two assistants needed

Technical requirements

Sound, Light and electricity: to be provided

Sound assistance required during the show

Other requirements:

- Parking space and possibly dressing room
- It is necessary to get to the spot by van to unload and upload materials
- Fix spot for the whole duration of the festival !!
- Shadow during the show

Design: Diego Polognioli

Dimensiones tripode

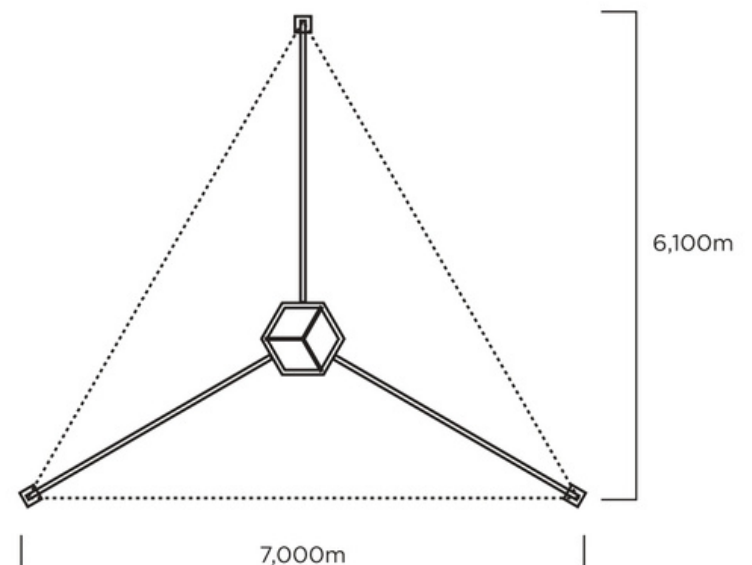
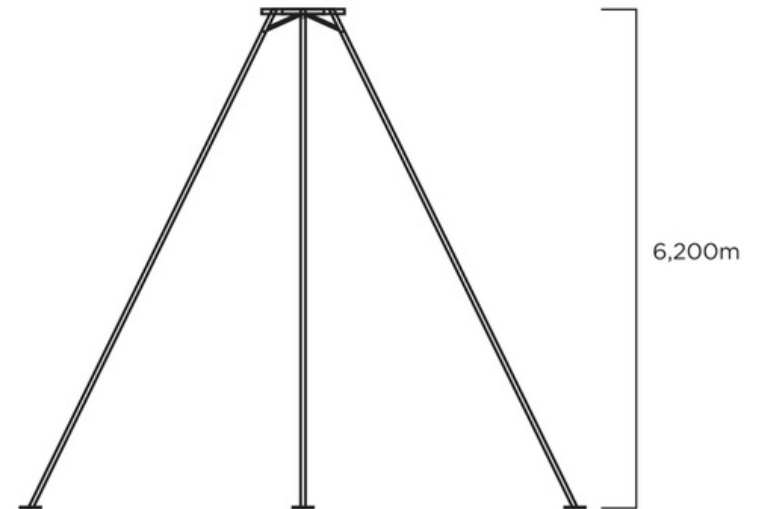

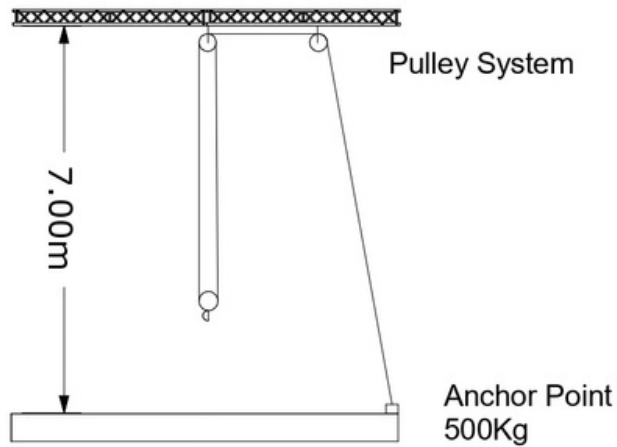

Indoor set up

Scenic space: 7mx7m

Height : ideal 6,5m/ 7m min

Rigging: anchor point required 500 kg
for a pulley system 2:2

Check picture

Public: half circle

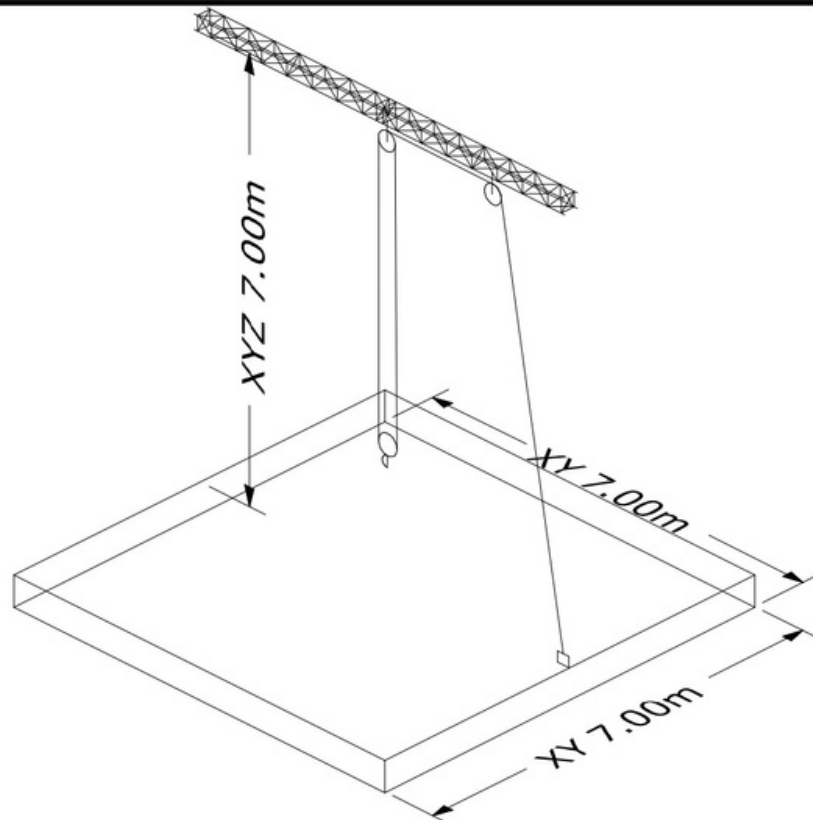

Set up aerials and stage: 1 hour

Light set up: to be arranged
according to the space

Warm up and preparation: 3 hours

Rehearse: 1hour

Show: 40 min

Desmantle aerials: 1 hour

Lights: to be designed

Light and Sound assistance required